

CHSN09L180M

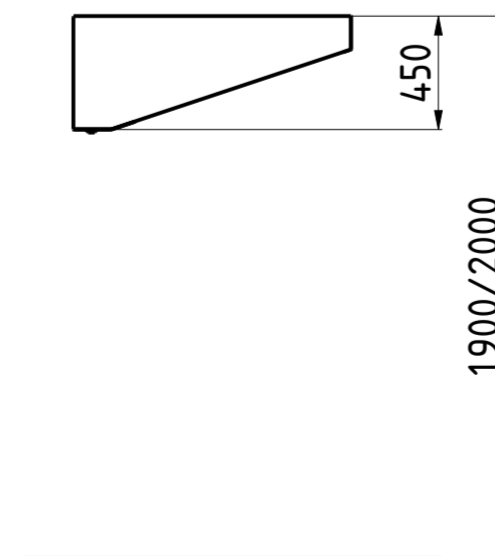

FORO AxB HOLE AxB	E	NR. LUCI NR. LIGHTS	PORTATA FLOW RATE	HST mmH:0	WATT	SDR	PESO (Kg) WEIGHT (Kg)
210x230	230	—	2040	4	147	7/7	75

DATA DATE	MODIF.N. MODIF.NO.	DESCRIZIONE MODIFICHE MODIFICATION DESCRIPTION	DISEGNATO DRAWN BY	APPROVATO APPROVED
MODELLO MODEL		CAPPA SNACK CON MOTORE 9/18 SNACK HOOD WITH MOTOR 9/18	SCALA SCALE	-
PARTICOLARE DETAIL		SCHEDA TECNICA DATA SHEET	DATA DATE	-
MATERIALE MATERIAL		AISI 304 - AISI 430	SPESS. THICK.	-
FINITURA FINISH			PEZZI N. PIECES NO.	
TRATTAMENTO TREATMENT			COLORE COLOUR	
			SHEET	1 OF 2
			ULTIMA EMISS. LAST EDITION	

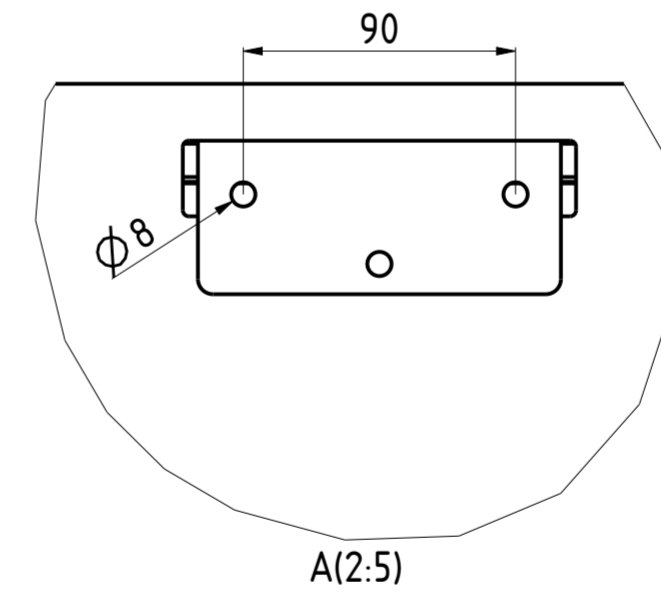
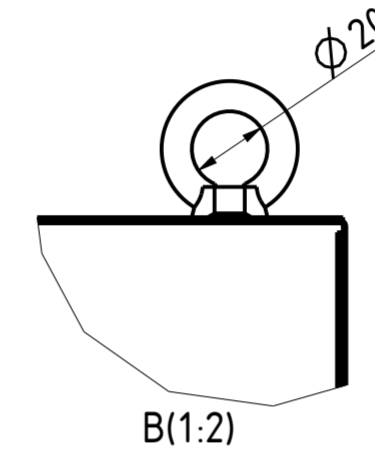
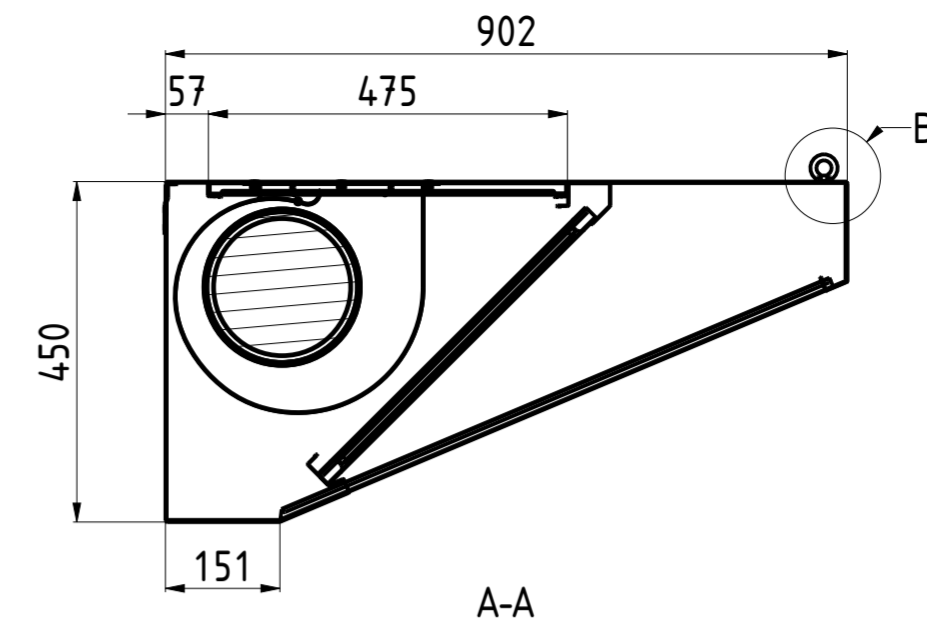
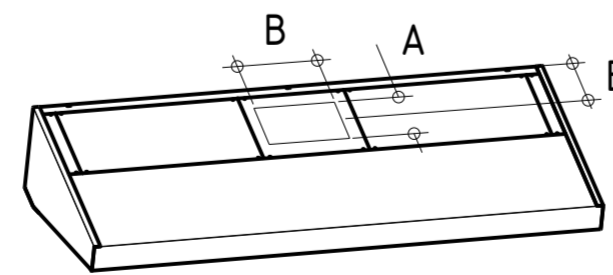
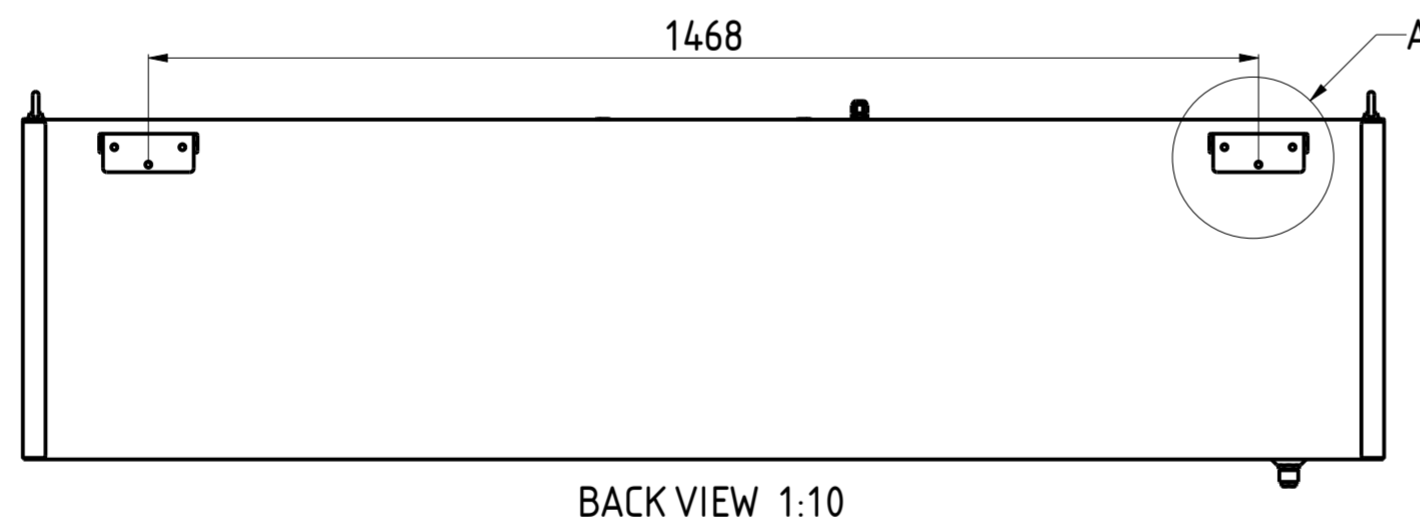
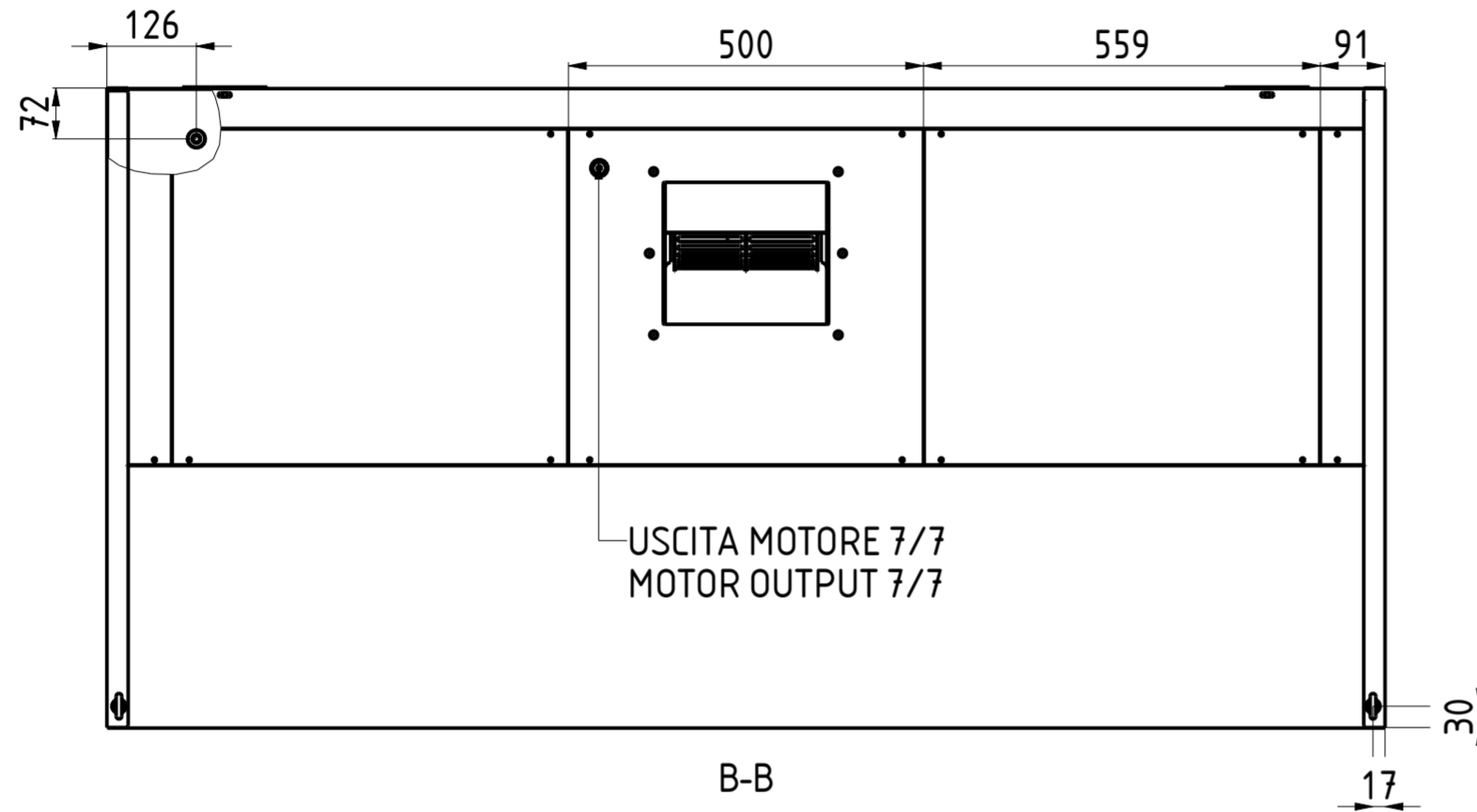
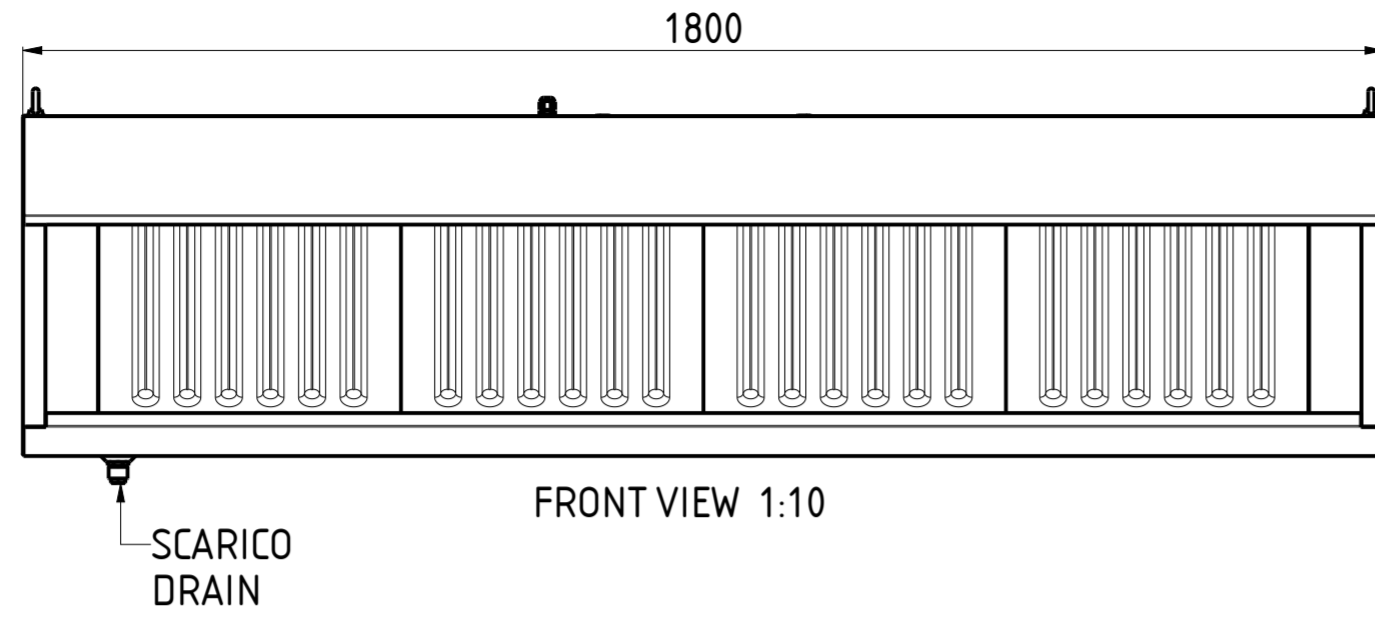
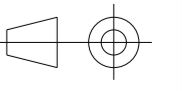

mm

FORM.A-2

ELABORATO CON SISTEMA CAD  
DESIGNED BY CAD/STEM

QUOTA PRIMARIA  
PRIMARY DIMENSION  
XX

ANGOLI  
Angles  
30°

TOLLERANCE UNLESS OTHERWISE STATED

QUOTE SENZA TOLLERANZA

LUNGH. E DIAM.  
LENGTH AND DIAM.